



## Synthesis of Carbon Nanotube : A Review

A.A. Rashad<sup>1</sup>, R. Noaman<sup>2</sup>, S.A. Mohammed<sup>3</sup>, E. Yousif<sup>1,\*</sup>

<sup>1</sup>Department of Chemistry, College of Science, Al-Nahrain University, Baghdad, Iraq.

<sup>2</sup>Chemical and Petrochemical Research Centre, Corporation of Research and Industrial Development, Ministry of Industry and Minerals, Baghdad, Iraq.

<sup>3</sup>College of Engineering and Architecture, University of Nizwa, Birkat Almouz, 616 Nizwa, Sultanate of Oman.

### ARTICLE DETAILS

#### Article history:

Received 04 May 2016

Accepted 14 June 2016

Available online 01 August 2016

#### Keywords:

Carbon Nanotube (CNT)

SWNT

MWNT

### ABSTRACT

Carbon nanotube represent one of the best novel nanostructures which have different individual structures, morphologies and properties, and carbon nanotube was been described as a sheet of graphite rolled into a hollow cylinder and the length and diameter depended on the conditions of synthesis method. The rolling of graphite sheet form two important structure multi-walled carbon nanotube (MWNT) and single-walled carbon nanotube (SWNT) where the two structure have special properties and wide application like chemical, biological, electrical, medical, sensor, physical and other application. A wide variety of synthesis methods have been developed to produce the carbon nanotube in huge quantity, more purities and selective structure.

### 1. Introduction

Carbon Nanotube are one of the allotropes of carbon which can be described as a sheet of graphite rolled into a hollow cylinder constructed from hexagonal rings of carbon with diameters ranging from one to tens of nanometers, and with lengths up to micrometer [1] as shown in Fig. 1.

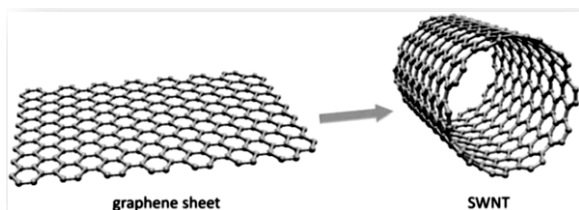

Fig. 1 Rolling of graphite sheets to formation carbon nanotube

Carbon nanotubes (CNTs) belong to relatively nanomaterial but their history is a little bit longer were firstly observed and described in 1952 by Radushkevich and Lukyanovich [2] and later in 1976 the single (or double) walled carbon nanotubes were observed by Oberlin et al [3] but carbon nanotubes were first discovered by Iijima in 1991[4] where he observed Carbon nanotubes that called multi-walled carbon nanotubes (MWNTs) (Fig. 2), Two years later, Iijima and Ichihashi of NEC [5] and Bethune and colleagues of the IBM Al maden Research Center in California[6] synthesized single-walled carbon nanotubes (SWNTs) as shown in Fig. 2. The appearance of SWNT is quite different to that of MWNT. The individual tubes have very small diameters (typically ~ 1nm) and curled or looped rather than straight [7-9] from their calculations, they found that SWNTs could be either metallic or semiconducting depending on their chirality and diameter [10, 11].

Bonding in nanotubes is essentially  $sp^2$ . The end tube may be curvature results in  $\sigma$ - $\pi$  rehybridization or mixing occasionally pentagons and heptagons are incorporated into a hexagonal network to form bent, branched, helical, or capped nanotubes whereas electrons will be localized in pentagons and heptagons because of redistribution of  $\pi$  electrons this makes nanotubes properties like mechanically stronger, electrically and

thermally more conductive, and chemically and biologically more active than graphite [12].

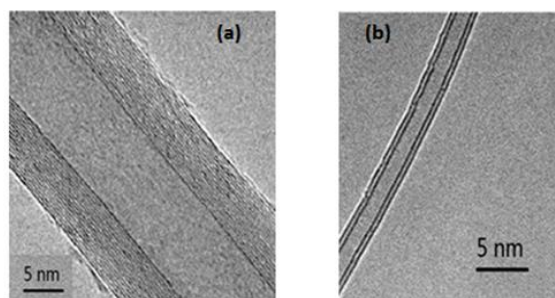

Fig. 2 TEM images (a) Multi Walled Nanotubes; (b) Single Walled Nanotube

The studying of the nanotube straight or elastic bending structures individually or in ropes [13] by transmission electron microscopy (TEM), scanning electron microscopy (SEM), atomic force microscopy (AFM), and scanning tunneling microscopy (STM). In addition, electron diffraction (EDR), x-ray diffraction (XRD), Raman, and other optical spectroscopy can be used to study structural features of nanotubes.

### 2. Types of Carbon Nanotubes and Related Structures

In general, a carbon nanotube was been classified into two major categories according to the number of ranging concentric tubes: Single-walled carbon nanotubes (SWNTs) and Multiwall carbon nanotubes (MWNTs) as appearance in Fig. 3.

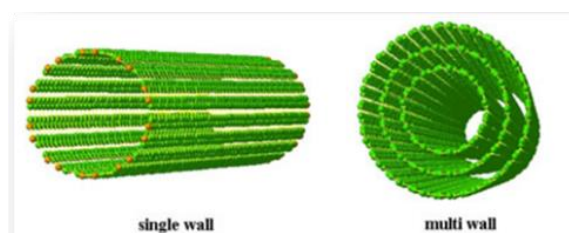

Fig. 3 3D-illustration of single walled and multi walled carbon nanotubes

\*Corresponding Author

Email Address: [emad\\_yousif@hotmail.com](mailto:emad_yousif@hotmail.com) (E. Yousif)

### 2.1 Single-Walled Carbon Nanotube (SWNT)

Single Walled Carbon Nanotube was formed by rolled-up sheet of graphene along a lattice vector in the plane (Fig. 4) and the tubes are normally capped at the ends. It was discovered by Iijima et al in 1993 [5, 6], the minimum diameter of a stable (0.4 nm) or larger (3.0 nm) and length ranging from tens of nanometers to centimeters. SWNTs can be formed as rope through a self-organization process in which Van der Waals force holds individual SWNTs together [13]. SWNT have versatile applications including transistors, conductive films, sensors, probes, mechanical reinforcements, hydrogen storage and catalytic supports because of their excellent electrical, mechanical, thermal, optical and biological properties. Carbon nanotube is form by rolling of a graphite sheet along the chiral vector. The chiral vector [14] can be determining the diameter and chirality of the tube and depending on the chirality. The geometrical structures of SWCNT can be classified into Armchair, Zig-Zag and Chiral nanotubes Fig. 4. Carbon nanotubes can be either a metal or a semiconductor according on the way of geometrical structures of carbon nanotube.

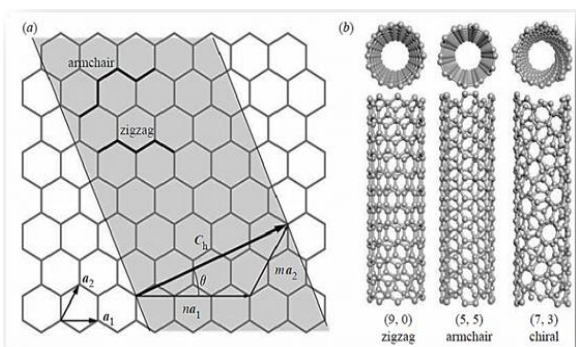

**Fig. 4** (a) Schematic of rolling a graphite sheet along the chiral vector to form Single-walled carbon nanotubes (b) Models of zigzag, armchair and chiral nanotubes

### 2.2 Double-Walled Carbon Nanotubes (DWCNTs)

Double-walled carbon nanotubes is the simplest type of MWNT where the structure consist of two coaxial hollow cylinders formed by two layers of rolled-up graphite ( Fig. 5). The typical interlayer space between the inner and the outer walls ranges from 0.33 nm to 0.42 nm. DWCNTs maintain the outstanding properties of SWNTs, but have several differences from simple SWNTs, such as higher stability, stiffness, optical properties and particular electronic [15].

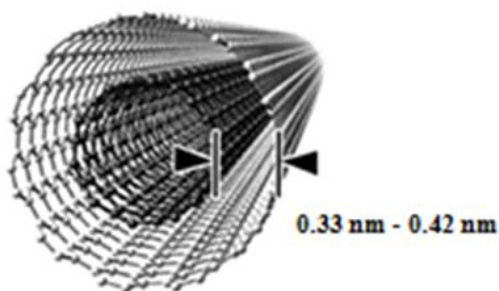

**Fig. 5** DWNT as a simplest example of MWNTs

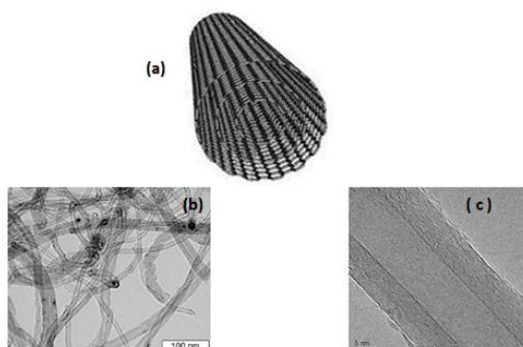

**Fig. 6** (a) Structure of multi-walled carbon nanotubes; (b), (c) TEM image of an individual multi walled carbon nanotube (MWNTs)

### 2.3 Multi-Walled Carbon Nanotubes (MWNT)

Multi-walled nanotubes (MWNT) consist of multiple layers of graphite superimposed which are rolled to form a tubular shape, have a number of walls ranging from two to less than a hundred. Iijima discovered MWNT in (1991) as shown in Fig. 6 [4]. MWNT diameter is larger than 2 nm inside and smaller than 100 nm outside [12], the distance between walls of neighboring tubes is comparable to the inter planar distance of graphite.

It is easier to produce significant quantities of MWNTs than SWNTs but their structures were been less well understood than single-wall nanotubes because of their greater complexity and variety.

## 3. Synthesis Methods of Carbon Nanotubes

There is a huge demand for quality nanotubes both as research materials and for large-scale industrial applications. The main problem with the currently available nanotubes is the heterogeneity of the sample, in terms of dimensions, chiral angles and purity; the preparation of high-quality carbon nanotubes with high yield has been the goal of many research endeavors. The CNTs can be produce using various methods that is summarizing in Fig. 7. Each of them has some advantages and disadvantages resulting in different growth results, which predestinates a choice of specific method for preparation of CNTs with requested properties.

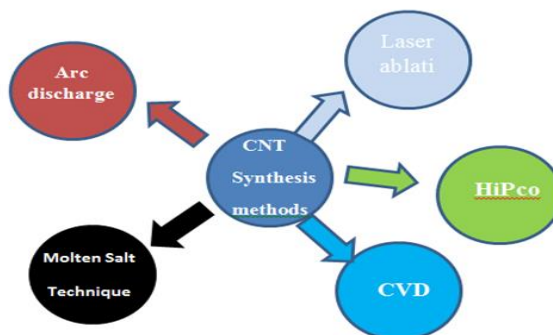

**Fig. 7** Some methods used for CNTs synthesis

To utilize carbon nanotubes on substrates in industrial applications, two main approaches have considered grow-in-place and grow-then-place.

#### 3.1 Grow-in-Place

This technique usually consists of preparing the sample with a catalyst present in the locations where the nanotubes would be synthesis (Fig. 8). For instance, a thin catalyst film can be deposited using several techniques for deposition like one-beam evaporation, PLD or sputtering, or nanoparticles can deposited on a substrate.

Synthesis is usually performed using thermal or assisted (e.g., plasma) Chemical Vapor Deposition (CVD) techniques.

The advantages of this synthesis method include:

- CNTs will grow where there are catalyst dots that make easy to control of growth nanotube position
- Proven recipes to obtain vertically aligned crystalline CNTs on insulating substrates
- The physical and the electrical contact with the substrate were good.
- The complementary metal-oxide-semiconductor (CMOS) industry was used experience CVD techniques

The major obstacle of the grow-in-place approach is the risk of damaging pre-existing structures during the synthesis

#### 3.2 Grow-then-Place

This technique consists of first preparing nanotubes and then transferring them to the target substrate (Fig. 8). Arc discharge and laser ablation are the main techniques used to synthesize substrate-free nanotubes.

The advantages of this method include:

- No restrictions on the process or temperature used for CNT synthesis
- Ability to pretreat CNTs (e.g., selects, purify, functionalize)

The major obstacle of the grow-then-place approach is the still insufficient level of repeatability and control to transfer the CNTs to specific regions of a substrate, which makes it an unlikely candidate for substrate-based applications (e.g., electronic devices).

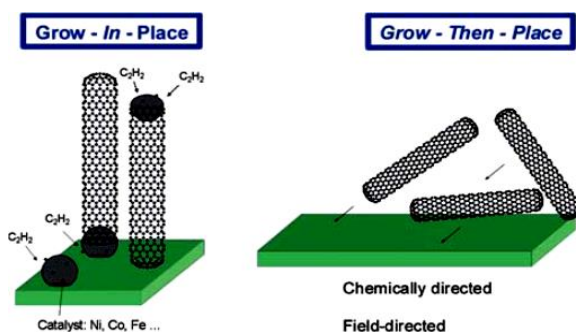

Fig. 8 Pictorials comparing the “grow-in-place” and “grow-then-place” techniques [16].

### 3.3 Arc Discharge Method

The arc discharge method is one of the simplest methods for synthesizing nanotubes on a large scale. The arc discharge depositions of CNTs are had done with or without use of different catalyst precursors. Usually the MWNTs are having produced when no catalyst is used; on the other hand, the SWNTs are had produced when the transition metal catalyst is used. Arc discharge belongs to the methods that use higher temperatures (Above 1700 °C) for CNT syntheses, which usually cause the growth of CNTs with a mixture of components, and requires further purification to separate the CNTs from the soot and the residual catalytic metals present in the crude product. This method creates CNTs through arc-vaporization of two graphite rods are have placed in an enclosure that is filled with some inert gas (like helium or argon) at low pressure (between 50 and 700 mbar) as shown in Fig. 9.

The carbon rods act as electrodes, which are having kept at different potentials. The anode is had moved close to the cathode until an arc appears and the electrodes are kept at the distance of 1 mm for the whole duration of the process that takes about one minute. After the depressurization and cooling of the chamber the nanotubes together with the by-products, can be collected. Most nanotubes deposit on the cathode. Recent investigations have shown that it is also possible to create CNTs with the arc method in liquid nitrogen [17]. Producing CNTs in high yield depends on:

- Nature and concentration of catalysts
- Gases composing the plasma
- Inert gas pressure
- Arc current intensity
- Distance between the electrodes

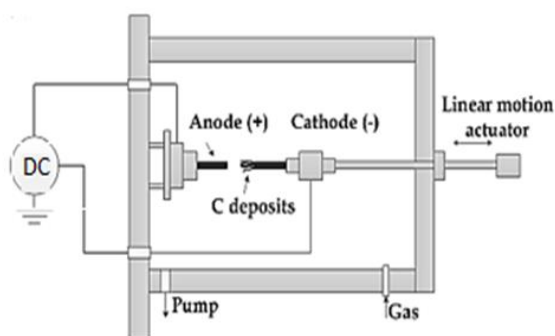

Fig. 9 Schematics diagram of an arc-discharge system

### 3.4 MWNTs Synthesis

The arc discharge synthesis of MWNTs is very simple, but high yields of tubes are difficult and require careful control of experimental conditions. The most utilized methods use DC arc discharge operates in a 1- to 4-mm wide gap between two graphite electrode 6 and 12 mm in diameters that are had vertically or horizontally installed in a water-cooled chamber filled with helium gas at sub atmospheric pressure. Gases and DC current are more important to maximize yield, the position of the electrode axis does not noticeably affect the MWNT quality or quantity.

The 50- to 250-mm long positive electrode (anode) is had consumed in the arc, whereas a cylindrically shaped cathode deposit (boule or slag) is grown on the negative electrode (cathode). The linear growth rate of the deposit along the cathode electrode is smaller than the rate of anode consumption, so one of the electrodes is had advanced automatically into the arc zone with a feed rate (FR) of about 0.5 to 3 mm/min to prevent gap

growth. The most stable and high yield arc process requires a constant feed rate and arc current for the duration of synthesis. The voltage measured on the electrode that leads outside the chamber grows during the run and the holders for the graphite cathode and anode rods are usually in water-cooled to prevent damage that might otherwise occur when the arc is near either the cathode or the anode holder. The cooling affects the properties of the cathode deposit only a few millimeters from its origin. The cathode use sufficiently small diameter (i.e., equal to or smaller than the anode rod diameter) that is long enough (i.e., a few centimeters) to more quickly attain a steady temperature at the cathode working surface and in the arc.

The purity and yield depended sensitively on the gas pressure in the reaction vessel [18]. Wang et al. showed that different atmospheres (He and methane) at various pressures markedly influence the final morphology of CNTs (Fig. 10), thick nanotubes embellished with many carbon nanoparticles were obtained [19]. Shimotani et al. reported synthesis of MWNTs under (He, ethanol, acetone and hexane) atmosphere at various pressures (from 150 to 500 Torr). They concluded that arc discharges in the three organic atmospheres (ethanol, acetone and hexane) produce more MWNTs, by two times at least, than those in the He atmosphere as the pressure increases up to 400 Torr [20]. Jiang et al. studied the influence of NH<sub>3</sub> atmosphere on the arc-discharge growth of CNTs, They concluded that there is no significant difference of the shapes and the structures between NH<sub>3</sub> atmosphere and other atmospheres such as He, H<sub>2</sub>, etc. [21].

The arc discharge deposition is had usually done as a DC arc discharge, but pulsed techniques were also reported. Tsai et al. also used single-pulse discharge in air. They obtained MWNTs with the outer diameter of 17 nm and an inner diameter of 5 nm using a peak current of 2.5 A and discharging time of 1000 ms [22]. Jung et al reported high yield synthesis of MWNTs by arc discharge in liquid nitrogen. They concluded that this technique can be a practical option for the large-scale synthesis of MWNTs with high purity [23].

Montoro et al reported the synthesis of high quality SWNTs and MWNTs through arc-discharge in H<sub>3</sub>VO<sub>4</sub> aqueous solution from pure graphite electrodes [24]. MWNTs were had synthesized in high yield by arc discharge in water between pure graphite electrodes by Guo et al [25].

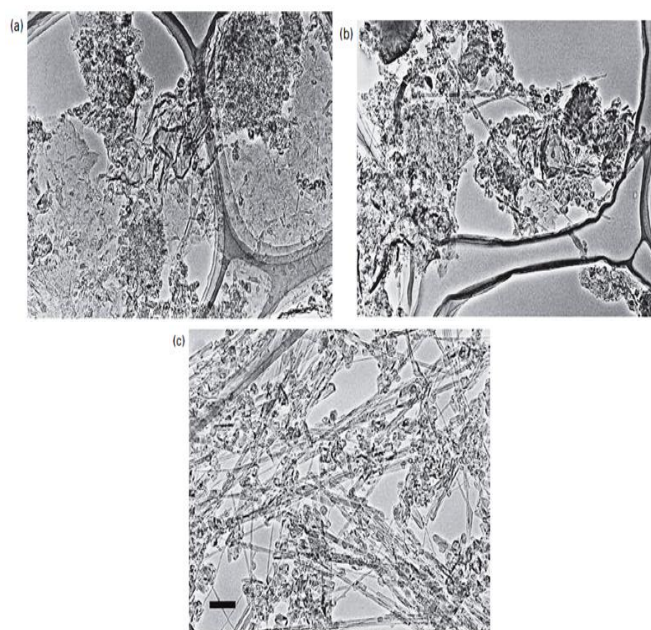

Fig. 10 Micrographs showing the effect of helium on the yield of nanotubes in arc-evaporation experiments, at (a) 20 torr, (b) 100 torr and (c) 500 torr

#### 3.4.1 SWNT Synthesis

The process of SWNTs growth in arc discharge utilizes a composite anode, usually in hydrogen or argon atmosphere. The anode was been made as a composition of graphite and a metal, such as Fe, Co, Ni, Cr, Mn, Cu, Pd, Pt, Ag, W, Ti, Hf, La, Ce, Pr, Nd, Tb, Dy, Ho, Er, Y, Lu, Gd, Li, B, Si, S, Se, Zn, Sn, Te, Bi, Cd, Ge, Sb, Pb, Al, In, Fe/Co, Fe/Ni, Fe/Co/Ni, Co/Ni, Co/Pt, Co/Cu, Co/Bi, Co/Pb, Co/Ru, Co/Y, Ni/Y, Ni/La, Ni/Lu, Ni/B, Ni/Mg, Ni/Cu, Ni/Ti [26–40], but at present only Ni/Y and Co/Ni catalysts are commonly used in SWNT production.

The metal catalyst plays a significant role in the process yield. To ensure high efficiency, the process also needs to be held on a constant gap distance between the electrodes, which ensures stable current density,

and anode consumption rate. In this process, unwanted products such as MWNTs or fullerenes are having produced too. A cylindrical deposit grows at the surface of the cathode. The weight of the deposit constitutes about one half of the weight of the anode consumed in the process. The deposit consists of a hard gray shell and a soft core.

Firstly, the SWNTs growth process was described in two separate works by Iijima and Ichihashi [5] who presented SWNTs of 1 nm and Bethune et al. who described Co catalyzed growth of SWNTs. Bethune et al reported that co-evaporation of carbon and cobalt in an arc generator leads to the formation of carbon nanotubes with very small diameters (about 1.2 nm) and walls made of a single atomic layer thick only [6]. In 1996 Saito et al reported the investigation of single layered nanotubes produced with platinum-group metals (Rh, Pd, and Pt) using arc discharge [41]. In another work, Saito et al produced SWNTs by the arc discharge method with Fe, Co, Ni, F/Ni, La, and Ce catalysts [42].

The arc discharge method is still in use for SWNTs synthesis, but usually with a new approach. Chen et al. reported the FH (ferrum-hydrogen) arc discharge method. Using this method, SWNTs are produced by a hydrogen DC arc discharge with evaporation of carbon anode containing 1% Fe catalyst in H<sub>2</sub>-Ar mixture gas. The as-grown SWNTs have high crystallinity. An oxidation purification process of as-grown SWNTs with H<sub>2</sub>O<sub>2</sub> may be developing to remove the coexisting Fe catalyst nanoparticles. As a result, SWNTs with purity higher than 90% has been achieved [43, 44]. Fan et al successfully produced SWNTs in argon DC arc discharge from charcoal as carbon source and FeS (20 wt %) as catalyst. According to SEM, TEM and Raman analysis, they achieved high purity SWNTs with diameter of about 1.2 nm. By this easy-to-get and relatively low cost material, the experimental results clearly indicated that charcoal has the opportunity of reducing the cost of SWNTs production [45]. In another work, Wang et al studied the role of Mo on the growth of SWNTs in the arc discharge method. They incorporated Mo into Ni/Y-He and Fe-Ar/H<sub>2</sub>, which are two typical arc systems. In both systems, Mo dramatically increased the yield of soot. The authors found that the purity of SWNTs did not change effectively for the Ni-Y/Mo-He system with the addition of Mo, but noticeable increment of purity was observed for Fe/Mo-Ar/H<sub>2</sub> system [46]. Li et al synthesis SWNTs in air by pulsed arc discharge by preheating the catalyst to 600 °C as an optimum that assists with the synthesis of SWNTs in air under pressure of 5–10 kPa. The SWNTs had a diameter of 1.5–2 nm and reached the length of several micrometers [47].

### 3.5 Laser Ablation Methods

In the laser ablation process, a pulsed laser was been made to strike at graphite target in a high temperature reactor in the presence of inert gas ~500 Torr pressure such as helium, which vaporizes a graphite target. The nanotubes develop on the cooler surfaces of the reactor, as the vaporized carbon condenses. A water-cooled surface is also included in the most practical systems to collect the nanotubes (Fig. 11). Laser ablation, is one of the superior methods to grow SWNTs with high quality and high-purity.

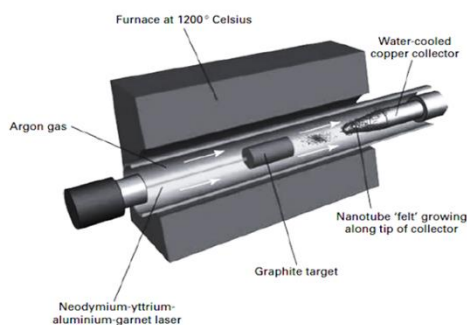

Fig. 11 Schematics of a laser ablation

In this method, which was first demonstrated by Smalley's group in 1995 using a dual-pulsed laser and achieved yields of > 70wt % purity of Single walled Carbon Nanotubes by laser ablation of graphite rods containing small amounts of Ni and Co at 1200 °C [48]. This method was used two-step laser ablation, initial laser vaporization pulse was follow by second pulse to vaporize target more rapidly. The two-step process minimizes the amount of carbon deposited as soot. Tubes grow in this method on catalyst atoms and continued to grow until too many catalyst atoms aggregate at the end of the tube. The tubes produced by this method are in the form of ropes 10 - 20 nm in diameter and up to 100 micron or more in length.

The studies realized until today showed that the quantity and the quality of produced material can be controlled to some extent by changing: (i) the type of metal catalysts and their ratio [49-51]; (ii) the kind of the ambient gas and its pressure [52-54]; (iii) the temperature of the reaction furnace [55-57]; and also (iv) the laser parameters [58-60].

### 3.5.1 Disadvantages of Arc-Discharge and Laser Ablation Produces

Both arc-discharge and laser ablation produces some of the most high quality nanotubes have disadvantages which limit their use as large-scale industrial processes.

1) Large amount of energy have be needed to produce arc or laser used for ablation processes.

2) Both methods require solid carbon/graphite as target, which has to be evaporating to get nanotubes. It is difficult to get such large graphite to been used as target in industrial process, which limits its exploitation as large-scale process.

3) Both processes grow nanotubes in highly tangled form, mixed with unwanted form of carbon or catalysts, which require purification to get purified and assembled forms.

### 3.6 Chemical Vapor Deposition

Chemical Vapor Deposition (CVD) allows synthesis of CNTs at lower temperatures compared to arc discharge and laser ablation, thus it is the most suitable candidate technique for CNT synthesis in the electronics and CMOS industry [61]. Chemical vapor deposition is the term used to describe heterogeneous reactions in which both solid and volatile products are form from a volatile precursor through chemical reactions, and the solid products are deposit on a substrate. Both MWNT and SWNT synthesis has been developed well using CVD and CVD methods allow more control over the morphology and structure of the produced nanotubes.

A variety of CVD processes have been used for CNTs synthesis, which include plasma-enhanced CVD, catalyst chemical CVD.

Carbon nanotube synthesis by CVD involves heating a catalyst material to a high temperature (550 to 1200 °C) in a quartz furnace and then flow a hydrocarbon gas through the tube reactor for a period. The catalytic species are transition metal nanoparticles typically supported on high surface area materials (alumina, silica or zeolite) materials (Fig. 12).

In thermal CVD, the heat of the furnace is responsible for the decomposition of the precursor gases in addition to affecting the catalytic function of the substrate.

The choice of catalyst is one of the most important parameters affecting the CNTs growth. Therefore, its preparation is also a crucial step in CNTs synthesis. Large amounts of CNTs can form by catalytic CVD of acetylene over cobalt and iron catalysts supported on silica or zeolite. The carbon deposition activity seems to relate to the cobalt content of the catalyst. Fullerenes and bundles of single walled nanotubes also found among the multi walled nanotubes produced on the carbon/zeolite catalyst. Some researchers are experimenting with the formation of CNTs from ethylene, Supported catalysts such as iron, cobalt, and nickel, containing either a single metal or a mixture of metals, seems to induce the growth of isolated single walled nanotubes or single walled nanotubes bundles in the ethylene atmosphere. The production of single walled nanotubes, as well as double-walled CNTs, on molybdenum and molybdenum-iron alloy catalysts are been demonstrated. CVD of carbon within the pores of a thin alumina template with or without a Nickel catalyst was been achieved. Ethylene was been used with reaction temperatures of 545 °C for Nickel-catalyzed CVD, and 900 °C for an unanalyzed process. The resultant carbon nanostructures have open ends. Methane also was been used as a carbon source. High yields of single walled nanotubes was been obtained by catalytic decomposition of an H<sub>2</sub>/CH<sub>4</sub> mixture over well-dispersed metal particles such as Cobalt, Nickel, and Iron on magnesium oxide at 1000 °C and CNTs can be achieved by selective reduction in an H<sub>2</sub>/CH<sub>4</sub> atmosphere of oxide solid solutions between a non-reducible oxide such as Al<sub>2</sub>O<sub>3</sub> or MgAl<sub>2</sub>O<sub>4</sub> and one or more transition metal oxides. The reduction produces very small transition metal particles at a temperature of usually >800 °C as shown in Fig. 12 [62].

Grazhulene et al prepared CNTs by CCVD using ethanol vapor as the carbon source and Ni as the catalyst. They demonstrated the CNTs adsorption capacity to a number of metal ions (Ag, Cu, Pb, Cd, Zn, Fe and Mg) regarding pH bath and element concentration in the solution. It was found that CNTs synthesized at 400 °C and treated with concentration HNO<sub>3</sub> in an autoclave at 110–120 °C possessed the maximum adsorption capacity of all studied elements, which exceeds the capacity of active coal, traditionally used for these purposes, by several times. The attained adsorption capacity is 5–10 times higher than that reported in the literature for CNTs in relation to the same elements. Thus, these CNTs

seem to be suitable as collectors for the pre-concentration of trace impurities in spectroscopic methods of analysis.

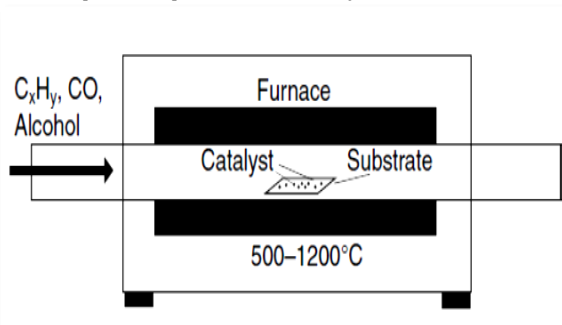

Fig. 12 Schematics diagram of the CVD furnace

Du et al synthesized CNTs by Co/MgO catalyzed pyrolysis of Dimethyl sulfide ( $C_2H_6S$ ) at 1000 °C, which is had used rarely as carbon source. The presence of sulfur can promote the growth of long SWNTs or is branched CNTs (BNTs). They found that  $C_2H_6S$  vapor concentration as well as flow rate in the reaction chamber determine the quality of the product. The authors also proposed the detailed growth mechanism of BNTs, which formed at high flow rate of  $C_2H_6S$  vapor [63].

### 3.7 Plasma Enhanced Chemical Vapor Deposition (PECVD)

Plasma-enhanced chemical vapor deposition methods have also been widely used for making carbon materials including MWNTs, Aligned Carbon Nanotubes and SWNT. The method is similar to arc-discharge in that both use ionized gas to reach the high temperature or low temperature necessary to vaporize carbon-containing substances and the transition metal catalyst (nickel, iron, cobalt, etc.) necessary for the ensuing nanotube growth. Carbon nanotube was growth perpendicular to the substrate could have achieved using the electrical field from plasma. Fig. 13 shows a schematic diagram of a typical plasma CVD apparatus with a parallel plate electrode structure. For the PECVD process, there are two main steps. First, the formation of nickel (Ni) catalyst islands on an oxidized (20 nm) silicon substrate through sintering at 650 °C. Second, nanotube growth from these discrete catalyst islands in a DC plasma discharge (bias -600 V) of acetylene and ammonia, at a pressure of 4 Torr. The initial thickness of the Ni catalyst layer controls the nanotube diameter and areal density. The plasma deposition time controls the nanotube height. A typical nanotube forest grown through this process has an areal density of 10 MWNTs per  $\mu m^2$ , with the vertical MWNTs having a mean diameter of 50 nm and a height of 2  $\mu m$ .

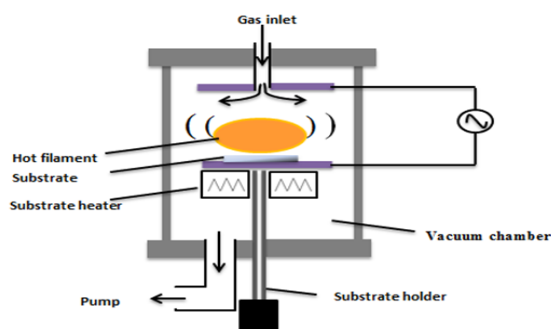

Fig. 13 Schematic diagram of plasma CVD apparatus

PECVD for high-quality SWNT synthesis is only recent and has been report by several groups. The reactive species in the plasma system could affect the growth of very small diameter tubes, with implications to both diameter control and selective etching of metallic SWNTs [64].

An example of the MWNTs forest-like structure deposited on solid substrate using PECVD was had shown in Fig. 14.

PECVD systems are characterize primarily by the plasma energy sources used, and the most commonly used include hot filament PECVD, direct current PECVD, radio frequency PECVD, and microwave PECVD.

Hot filament PECVD uses thermal energy for plasma creation and is been used successfully for carbon nanotube production by Ren and co-workers successful growth of large-scale well-aligned carbon nanofibres on nickel foils and nickel-coated glass at temperatures below 666 °C [65].

Microwave PECVD, widely used for the preparation of diamond films, has also been successfully used in the production of carbon nanotubes,

Bower et al [66-70] have grown well-aligned carbon nanotubes using microwave PECVD with additional radio frequency graphite heater. They found that switching the plasma source off effectively turns the alignment mechanism off leading to the thermal growth of curly nanotubes. Synthesis of vertically aligned CNTs requires electric field normal to the substrate, and DC PECVD is the most suitable method to achieve this [71, 72]. Inductively coupled plasma PECVD [73, 74] and radio frequency PECVD [75, 76].

In plasma enhanced CVD systems, plasma energy sources substitute for the thermal energy in a furnace, and provide the energy required for decomposition of hydrocarbon feedstock and allow growth of carbon nanostructures at much lower temperatures.

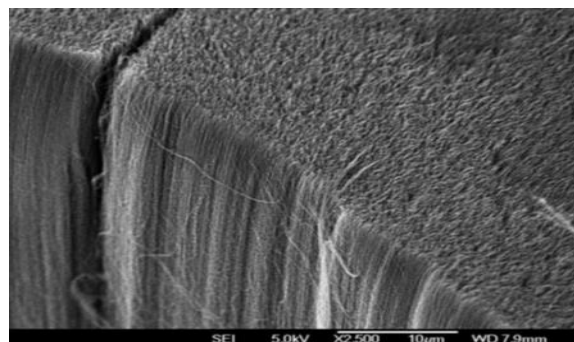

Fig. 14 SEM image of MWNTs forest deposited using PECVD at atmospheric pressure

### 3.8 High Pressure CO Disproportionation Process (HiPCO)

In the HiPco process, nanotubes grow in high-pressure, high-temperature flowing CO on catalytic clusters of iron. The catalyst is formed in situ by the thermal decomposition of  $Fe(CO)_5$ , which is delivered intact within a cold CO flow and then rapidly mixed with hot CO in the reaction zone. Upon heating, the  $Fe(CO)_5$  decomposes into atoms which condense into larger clusters. SWNTs nucleate and grow on these particles in the gas phase via CO disproportionation catalyzed by the Fe surface. The rate of the CO disproportionation scales as a square of CO pressure, hence the importance of high-pressure CO for efficient SWNT production (Fig. 15).



Dai et al performed the first CVD synthesis of SWNTs by Mo-catalyzed disproportionation of CO at 1200 °C in 1996 [77].

It was report that most of the resulting SWNTs had catalytic particles attached to the ends, indicating that the growth of SWNTs was catalyst by preformed nanoparticles. The use of CO as a feed gas does offer certain advantages over hydrocarbons. Compared with samples made using the same catalyst and methane, the amount of amorphous carbon can reduced.

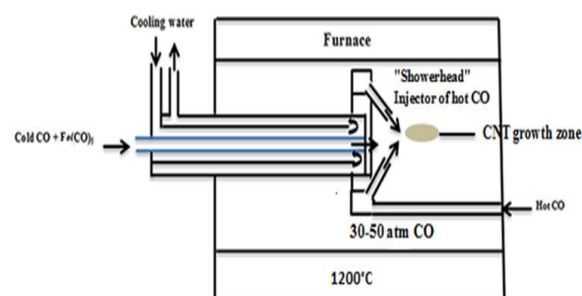

Fig. 15 Schematic diagram of High-pressure CO disproportionation process

### 3.9 Molten Salt Technique

Hsu, Kroto and their co-workers of Sussex University in the UK discovered a newly developed recent development in electrolytic formation of carbon nanotubes in molten salts in 1995 they obtained carbon nanotubes by electrolysis of molten lithium chloride using a high-purity carbon cathode [78, 79]. The electrolytic method is the first example of CNTs is being produce in the condensed phase. Around the world in the past few years, the process of CNTs from molten melt is being reduction of gathering forces. More impartment the cost for the energy consumption of electrolysis is very low in comparison with that material consumption, i.e. graphite and molten salt. In addition to the low energy consumption and

use of cheap raw materials, the electrolytic method has the advantage of being potentially continuous process. Electrolytic produced CNTs yield was mainly depend strongly on electrolysis, time, current, voltage and temperature of the bath. The electrolytic CNTs will become gradually more attractive because of the device and operational simplicity and feasible continuity method. Electrolytic CNTs preparation can have promising in future and compete with other CNT production technologies [80].

#### 4. Discussion

The CNT purification necessitates removal of carbonaceous (amorphous and graphitic), catalyst particles and other unwanted species that produced in the synthesis together with carbon nanotube. Purification methods consist of one or more of the following steps: Dispersion, oxidation (thermal/microwave), wet oxidation/ chemical treatment, filtration (including chromatographic methods) and annealing technique such as ultra-sonication is use mainly for dispersion. Even after dispersion, direct acid treatment is less effective for removal of catalyst particles due to carbonaceous coating over them.

Oxidation is couple with dry oxidation to break carbon shell and expose catalyst surface for acid attack. This step needs strict control on oxidation temperature, as in presence of oxygen, the metal particle catalyze indiscriminate oxidation of carbon and ultimately destroy the CNTs. To circumvent this problem, Chiang et al [81, 82] proposed a scheme that begins with long, low-temperature oxidative cracking of the carbonaceous shells encapsulating the metal particles. This was had done with wet oxygen by bubbling 20 per cent O<sub>2</sub> in argon through water. This process effectively removes carbon coating over metal particles, which are had then easily dissolved by acid treatment. Microwave heating [83, 84] has also been employed to break carbon coating over metal particles enabling efficient removal of catalyst in acid treatment step.

Acid treatment step poses two challenges: (a) to remove reaction products coated on the CNT surface, and (b) to restore CNT structure damaged by rigorous acid treatment.

Refluxing the sample in acid is effective in reducing the amount of metal particles and amorphous carbon. Different used acids are hydrochloric acid (HCl), nitric acid (HNO<sub>3</sub>) and sulphuric acid (H<sub>2</sub>SO<sub>4</sub>), while HCl is identify to be the ideal refluxing acid. When a treatment in HNO<sub>3</sub> had been use the acid had an effect on the metal catalyst only and no effects was observe on the CNTs and the other carbon particles [85-88]. For removal of reaction products, when starting material is small (e.g., milligrams), the CNTs can be vacuum filtered, followed by washing with a dilute base to remove the nanoparticles (rendered soluble in the base by functionalization with carboxylic groups). For larger (gram) quantities, vacuum filtration becomes untenable because of the complex filtration path formed by the overlapping nanotubes, making the permeate flow rate extremely slow. In this case, bulk of acid is decanted, followed by repeated cycles of centrifugation, decanting of the supernatant solution, and re-suspension in deionized water for further neutralize the reaction products.

The buffer solution along with surfactant is had added to keep the naturally hydrophobic nanotubes from agglomerating.

The surfactants used are easy to remove by washing with either water or methanol. Amorphous carbon impurities and metal catalysts in the raw CNTs can then be removed by centrifugation and filtration.

Murphy et al [89] reported the use of a conjugated polymer host system to extract the graphitic particle impurities from CNT soot produced by the arc discharge method. The polymer extraction technique is clime to be nondestructive because it does not rely on the difference in the oxidation reaction rates for the crystalline graphitic structures vs the amorphous carbon impurities.

The most effective procedure to date has been reports by Cinke et al [90] with a final Fe content of ~0.4%, and this procedure is describe below:

The procedure of purification, which has been reported by Cinke et al, consists of two steps. The first step, designed to de bundle the nanotubes, involves suspending raw SWNTs in a mixture of 200 mL DMF (dimethyl formamide) and 100  $\mu$ L EDA (ethylene diamine), and this solution was stirred for 18 h followed by a 6.5 h sonication. The solution then was been centrifuged and the solvent mixture was decanted. The precipitates were been centrifuged and decanted twice with methanol as the washing solvent. The entire procedure was been repeated once more. The amine and amide groups in these solvents can interact with the  $\pi$ -electrons on the surface of the CNTs. Therefore, this procedure helps loosen the nanotube bundles. In the second step, the DMF/EDA treated SWNTs were been suspended in 250 mL of 37% HCl and sonicated for 15 minutes to get the nanotubes dissolved. The stirred solution was been heated to 45 °C for 2 h. The solution was been diluted with double distilled water and cooled

to room temperature because the centrifuge tubes cannot tolerate a high concentration of acid. The solution was been centrifuged and decanted four times with double distilled water.

The SWNTs were had dried in air and placed in a quartz boat located at the center of a quartz tube connected to a water bubbler. A stream of wet air was been fed into the quartz tube with the tube maintained at 225 °C for 18 h, and then the SWNTs were cooled to room temperature. The HCl treatment removes the metals, and the wet-air oxidation removes the amorphous carbon. The combined two-step effort has yielded the largest surface area for SWNTs to date with 1567 m<sup>2</sup>/gm.

Recently, Shim et al [91] devised an integrated scheme to purify MWNTs using electrophoresis induced by the application of an AC electric field to a set of microelectrodes in a micro liquid channel. This purifying method is different from conventional methods based on chemical processes and has potential applicability in the development of micro devices that can simultaneously perform the purification and fabrication of MWNTs. For restoration of the CNT structure, annealing of purified sample under vacuum or inert atmosphere is had carried out [92, 93].

The current liquid-phase purification procedure follows certain essential steps: preliminary filtration- to get rid of large graphite particles; dissolution- to remove fullerenes (in organic solvents) and catalyst particles (in concentrated acids), centrifugal separation, microfiltration and chromatography. It is important to keep the CNTs well separated in solution, so the CNTs are typically disperse using a surfactant prior to the last stage of separation.

#### 5. Conclusion

There are many type synthesis methods of carbon nanotube and each type has advantage and disadvantage to production of carbon nanotube. The condition of synthesis determine the amount and the type of production of carbon nanotube.

#### Acknowledgements

The authors thank Al-Nahrain University and Ministry of Industry and Minerals and University of Nizwa and for continued support.

#### References

- [1] Z. Wang, G. Salamo, N. Kishimoto, Physical properties of ceramic and carbon nanoscale structures, Springer-Verlag, Berlin, 2011.
- [2] L.V. Radushkevich, V.M. Lukyanovich, The structure of carbon formed by thermal decomposition of carbon oxide on an iron contact, Russian J. Phy. Chem. A 26 (1952) 88-95.
- [3] A. Oberlin, M. Endo, T. Koyama, Filamentous growth of carbon through benzene decomposition, J. Crystal Growth 32 (1976) 335-349.
- [4] S. Iijima, Helical microtubules of graphitic carbon, Nature 354(1991) 56-58.
- [5] S. Iijima, T. Ichihashi, Single-shell carbon nanotubes of 1-nm diameter, Nature 363 (1993) 603-605.
- [6] D.S. Bethune, C.H. Kiang, M.S. De Vries, G. Gorman, R. Savoy, J. Vazquez, R. Beyers, Cobalt-catalyzed growth of carbon nanotubes with single-atomic layer walls, Nature 363 (1993) 605-607.
- [7] N. Hamada, S. Sawada, A. Oshiyama, New one-dimensional conductors: Graphitic microtubules, J. Phys. Rev. Lett. 68 (1992) 1579-1582.
- [8] R. Saito, M. Fujita, G. Dresselhaus, M.S. Dresselhaus, Electronic structure of graphene tubules based on C<sub>60</sub>, Phys. Rev. Lett. B 46 (1992) 1804-181.
- [9] R. Saito, M. Fujita, G. Dresselhaus, M.S. Dresselhaus, Electronic structure of chiral graphene tubules, Appl. Phys. Lett. 60 (1992) 2204-2206.
- [10] J.W.G. Wildoer, L.C. Venema, A.G. Rinzler, R.E. Smalley, C. Dekker, Electronic structure of atomically resolved carbon nanotubes, Nature 391 (1998) 59-62.
- [11] T.W. Odom, J.L. Huang, P. Kim, C.M. Lieber, Atomic structure and electronic properties of single-walled carbon nanotubes, Nature 391 (1998) 62-64.
- [12] M. Meyyappan, Carbon nanotube science and application, CRC Press LLC, New York, 2005.
- [13] A. Thess, Crystalline ropes of metallic carbon nanotubes, Science 273 (1996) 483-487.
- [14] A. Kis, A. Zettl, Nanomechanics of carbon nanotubes, Philosophical Trans. Royal Soc. A 366 (2008) 1591-1611.
- [15] P. Rudolf, P. Thomas, A.K. Yoong, K. Hans, Double-Wall carbon nanotubes, Springer berlin, Heidelberg, 2008.
- [16] C.V. Thompson, Carbon nanotubes as interconnects: emerging technology and potential reliability issues, 46<sup>th</sup> International Reliability Symposium, IEEE CFP08RPS-PRT, Piscataway, New Jersey, 2008.
- [17] M. Wilson, K. Kannangara, G. Smith, M. Simmons, Bu. Raguse, Nanotechnology: Basic science and emerging technologies, CRC Press Company, Florida, 2002.
- [18] T.W. Ebbesen, P.M. Ajayan, Large-scale synthesis of carbon nanotubes, Nature 358 (6383) (1992) 220-222.
- [19] M. Wang, X.L. Zhao, M. Ohkohchi, Y. Ando, Carbon nanotubes grown on the surface of cathode deposit by arc discharge, Fullerene Sci. Technol. 4 (1996) 1027-1039.
- [20] K. Shimotani, K. Anazawa, H. Watanabe, M. Shimizu, New synthesis of multi-walled carbon nanotubes using an arc discharge technique under organic

- molecular atmospheres, *J. Appl. Phys. A: Mater. Sci. Proc.* 73 (4) (2001) 451-454.
- [21] Y. Jiang, H. Wang, X.F. Shang, Z.H. Li, M. Wang, Influence of  $\text{NH}_3$  atmosphere on the growth and structures of carbon nanotubes synthesized by the arc-discharge method, *J. Inorg. Mater.* 45 (2009) 1237-1239.
- [22] Y.Y. Tsai, J.S. Su, C.Y. Su, W.H. He, Production of carbon nanotubes by single-pulse discharge in air, *J. Mater. Proc. Technol.* 209(9) (2009) 4413-4416.
- [23] S.H. Jung, M.R. Kim, S.H. Jeong, High-yield synthesis of multi-walled carbon nanotubes by arc discharge in liquid nitrogen, *J. Appl. Phys. A: Mater. Sci. Proc.* 76(2) (2003) 285-286.
- [24] L.A. Montoro, R.C.Z. Lofrano, J.M. Rosolen, Synthesis of single-walled and multi-walled carbon nanotubes by arc-water method, *Carbon* 43 (2005) 200-203.
- [25] J.J. Guo, X.M. Wang, Y.L. Yao, X.W. Yang, X.G. Liu, B.S. Xu, Structure of nanocarbons prepared by arc discharge in water, *J. Chem. Phys.* 105(2) (2007) 175-178.
- [26] P.M. Ajayan, Growth morphologies during cobalt-catalyzed single-shell carbon nanotube synthesis, *J. Chem. Phys. Lett.* 215 (1993) 509-516.
- [27] S. Serapin, Catalytic role of nickel, palladium and platinum in the formation of carbon nanoclusters, *J. Chem. Phys. Lett.* 217(3) (1994) 191-198.
- [28] S. Serapin, D. Zhou, Single-walled carbon nanotubes produced at high-yield by mixed catalysts, *Appl. Phys. Lett.* 64 (1994) 2087-2095.
- [29] C.H. Kiang, Catalytic synthesis of single-layer carbon nanotubes with a wide range of diameters, *J. Phys. Chem.* 98 (1994) 6612-6619.
- [30] J.M. Lambert, Improving conditions towards isolating single-shell carbon nanotubes, *J. Chem. Phys. Lett.* 226 (1994) 364-369.
- [31] X. Lin, Large scale synthesis of single-shell carbon nanotubes, *Appl. Phys. Lett.* 64 (1994) 181-183.
- [32] P.M. Ajayan, Growth of manganese filled carbon nanofibers in the vapor phase, *Phys. Rev. Lett.* 72 (1994) 1722-1731.
- [33] C. Guerret-Piecourt, Relation between metal electronic structure and morphology of metal compounds inside carbon nanotubes, *Nature*, 372(1994) 761-768.
- [34] C.H. Kiang, Carbon nanotubes with single-layer walls, *Carbon*, 33 (1995) 903-907.
- [35] Y. Saito, K. Kawabata, M. Okuda, single-layered carbon nanotubes synthesized by catalytic assistance of rare-earths in a carbon arc, *J. Phys. Chem.* 99 (1995) 16076-16079.
- [36] J. Lambert, P. Ajayan, P. Bernier, Synthesis of single and multi-shell carbon nanotubes, *Synth. Metals* 70 (1995) 1475-1476.
- [37] M. Ata, Carbon nanotubes filled with gadolinium and hafnium carbides, *J. Appl. Phys.* 34(8A) (1995) 4207-4212.
- [38] W.K. Maser, Elaboration and characterization of various carbon nanostructures, *Synth. Metals* 81 (1996) 243-250.
- [39] A. Loiseau, H. Pascard, Synthesis of long carbon nanotubes filled with Se, S, Sb and Ge by the arc method, *J. Chem. Phys. Lett.* 256 (1996) 246-251.
- [40] C. Journet, Large-scale production of single-walled carbon nanotubes by the electric-arc technique, *Nature* 388(6644) (1997) 756-758.
- [41] Y. Saito, K. Nishikubo, K. Kawabata, T. Matsumoto, Carbon nanocapsules and single-layered nanotubes produced with platinum-group metals (Ru, Rh, Pd, Os, Ir, Pt) by arc discharge, *J. Appl. Phys.* 80(5) (1996) 3062-3067.
- [42] Y. Saito, M. Okuda, T. Koyama, Carbon nanocapsules and single-wall nanotubes formed by arc evaporation, *Surf. Rev. Lett.* 3 (1996) 863-867.
- [43] B. Chen, X. Zhao, S. Inoue, Y. Ando, Fabrication and dispersion evaluation of single-wall carbon nanotubes produced by FH-Arc discharge method, *J. Nanosci. Nanotechnol.* 10 (2010) 3973-3977.
- [44] B. Chen, S. Inoue, Y. Ando, Raman spectroscopic and thermogravimetric studies of high-crystallinity SWNTs synthesized by FH-arc discharge method, *J. Diam. Relat. Mater.* 18(5) (2009) 975-978.
- [45] W.W. Fan, J. Zhao, Y.K. Lv, W.R. Bao, X.G. Liu, Synthesis of SWNTs from charcoal by arc-discharging, *J. Wuhan Univ. Technol.* 25 (2010) 194-196.
- [46] H.F. Wang, Z.H. Li, S. Inoue, Y. Ando, Influence of Mo on the growth of single-walled carbon nanotubes in arc discharge, *J. Nanosci. Nanotechnol.* 10 (2010) 3988-3993.
- [47] Z.J. Li, P. Liu, B. Zhao, H.Y. Wang, Y.F. Zhang, Improving the synthesis of single-walled carbon nanotubes by pulsed arc discharge in air by preheating the catalysts, *Carbon* 46 (2008) 1819-1822.
- [48] T. Guo, P. Nikolaev, A. Thess, D.T. Colbert, R.E. Smalley, Direct measurement of the rotational g-value in the ground vibrational state of acetylene by magnetic vibrational circular dichroism, *J. Chem. Phys. Lett.* 243 (1995) 49-54.
- [49] M. Yudasaka, R. Yamada, N. Sensui, T. Wilkins, T. Ichihashi, S. Iijima, Mechanism of the effect of NiCo, Ni and Co catalysts on the yield of single-wall carbon nanotubes formed by pulsed Nd:YAG laser ablation, *J. Chem. Phys. B* 103 (1999) 6224-6229.
- [50] M. Zhang, M. Yudasaka, S. Iijima, Single-wall carbon nanotubes: a high yield of tubes through laser ablation of a crude-tube target, *J. Chem. Phys. Lett.* 336 (2001) 196-200.
- [51] H. Kataura, Y. Kumazawa, Y. Maniwa, Y. Ohtsuka, R. Sen, S. Suzuki, Y. Achiba, Diameter control of single-walled carbon nanotubes, *Carbon* 38 (2000) 1691-1697.
- [52] D. Nishide, H. Kataura, S. Suzuki, K. Tsukagoshi, Y. Aoyagi, Y. Achiba, High-yield production of single-wall carbon nanotubes in nitrogen gas, *J. Chem. Phys. Lett.* 372 (2003) 45-50.
- [53] M. Yudasaka, T. Komatsu, T. Ichihashi, Y. Achiba, S. Iijima, Pressure dependence of the structures of carbonaceous deposits formed by laser ablation on targets composed of carbon, nickel, and cobalt, *J. Chem. Phys.* 102 (1998) 4892-4896.
- [54] A.A. Gorbunov, R. Friedlein, O. Jost, M.S. Golden, J. Fink, W. Pompe, Gas-dynamic consideration of the laser evaporation synthesis of single-wall carbon nanotubes, *J. Appl. Phys. A (Suppl.)* 69 (1999) S593-S596.
- [55] N. Braid, M.A. El Khakani, G.A. Botton, Effect of laser intensity on yield and physical characteristics of single wall carbon nanotubes produced by the Nd:YAG laser vaporization method, *Carbon*, 40(2002) 2835-2842.
- [56] F. Kokai, K. Takahashi, M. Yudasaka, R. Yamada, T. Ichihashi, S. Iijima, Growth dynamics of single-wall carbon nanotubes synthesized by  $\text{CO}_2$  laser vaporization, *J. Chem. Phys. B*, 103(1999) 4346-4351.
- [57] S. Bandow, S. Asaka, Y.A.M. Rao, L. Grigorian, E. Richter, P.C. Eklund, effect of the growth temperature on the diameter distribution and chirality of single-wall carbon nanotubes, *J. Phys. Rev. Lett.* 80 (1998) 3779-3782.
- [58] A.C. Dillon, P.A. Parilla, J.L. Alleman, J.D. Perkins, M.J. Heben, Controlling single-wall nanotube diameters with variation in laser pulse power, *J. Chem. Phys. Lett.* 316 (2000) 13-18.
- [59] M. Yudasaka, T. Ichihashi, T. Komatsu, S. Iijima, Single-wall carbon nanotubes formed by a single laser-beam pulse, *J. Chem. Phys. Lett.* 299 (1999) 91-96.
- [60] H. Zhang, Y. Ding, Y. Chen, Y. Zhu, S. Zhong, The effect of laser power on the formation of carbon nanotubes prepared in  $\text{CO}_2$  continuous wave laser ablation at room temperature, *J. Phys. B* 325 (2003) 224-229.
- [61] C. Emmenegger, J.M. Bonard, P. Mauron, P. Sudan, A. Lepora, B. Grobety, A. Zeutzel, L. Schlapbach, Synthesis of carbon nanotubes over Fe catalyst on aluminium and suggested growth mechanism, *Carbon* 41(3) (2003) 539-547.
- [62] O'Connell, Carbon nanotubes properties and applications, Taylor and Francis Group, LLC, New York, 2006.
- [63] S.S. Grazhulene, A.N. Red'kin, G.F. Telegin, A.V. Bazhenov, T.N. Fursova, Adsorption properties of carbon nanotubes depending on the temperature of their synthesis and subsequent treatment, *J. Anal. Chem.* 65(7) (2010) 682-689.
- [64] A.V. Melechko, V.I. Merkulov, T.E. McKnight, M.A. Guillorn, K.L. Klein, D.H. Lowndes, M.L. Simpson, Vertically aligned carbon nanofibers and related structures: Controlled synthesis and directed assembly, *J. Appl. Phys.* 97 (2005) 041301-39.
- [65] Z.F. Ren, Z.P. Huang, P. Bush, M.P. Siegal, P.N. Provencio, Synthesis of large arrays of well-aligned carbon nanotubes on glass, *Science* 282 (1998) 1105-1107.
- [66] L.C. Qin, D. Zhou, A.R. Krauss, D.M. Gruen, Growing carbon nanotubes by microwave plasma-enhanced chemical vapor deposition, *J. Appl. Phys. Lett.* 72 (1998) 3437-3439.
- [67] S.H. Tsai, C.W. Chao, C.L. Lee, H.C. Shih, plasmas and electrical discharges - Bias-enhanced nucleation and growth of the aligned carbon nanotubes with open ends under microwave plasma synthesis, *J. Appl. Phys. Lett.* 74 (1999) 3462-3464.
- [68] Y.C. Choi, Y.M. Shin, Y.H. Lee, B.S. Lee, G.S. Park, W.B. Choi, et al, Controlling the diameter, growth rate, and density of vertically aligned carbon nanotubes synthesized by microwave plasma-enhanced chemical vapor deposition, *Appl. Phys. Lett.* 76 (2000) 2367-2369.
- [69] C. Bower, W. Zhu, S. Jin, O. Zhou, Plasma-induced alignment of carbon nanotubes, *J. Appl. Phys. Lett.* 77(2000) 830-832.
- [70] M. Okai, T. Muneyoshi, T. Yaguchi, S. Sasaki, Structure of carbon nanotubes grown by microwave-plasma-enhanced chemical vapor deposition, *J. Appl. Phys. Lett.* 77 (2000) 3468-3470.
- [71] K.B.K. Teo, M. Chhowalla, G.A.J. Amaratunga, W.I. Milne, G. Pirio, P. Legagneux, et al, Field emission from dense, sparse, and patterned arrays of carbon nanofibers, *Appl. Phys. Lett.* 80 (2002) 2011-2013.
- [72] M. Chhowalla, K.B.K. Teo, C. Ducati, N.L. Rupasinghe, G.A.J. Amaratunga, A.C. Ferrari, et al, Growth process conditions of vertically aligned carbon nanotubes using plasma enhanced chemical vapor deposition, *J. Appl. Phys.* 90 (2001) 5308-5317.
- [73] J. Li, R. Stevens, L. Delzeit, H.T. Ng, A. Cassell, J. Han, M. Meyyappan, Electronic properties of multiwalled carbon nanotubes in an embedded vertical array, *Appl. Phys. Lett.* 81(5) (2002) 910-912.
- [74] L. Delzeit, I. McAninch, B.A. Cruden, D. Hash, B. Chen, J. Han, M. Meyyappan, Growth of multiwall carbon nanotubes in an inductively coupled plasma reactor, *J. Appl. Phys.* 91 (2002) 6027-6033.
- [75] Y.H. Wang, J. Lin, C.H. Huan, G.S. Chen, Synthesis of large area aligned carbon nanotube arrays from  $\text{C}_2\text{H}_2\text{-H}_2\text{C}_2\text{H}_2\text{-H}_2$  mixture by rf plasma-enhanced chemical vapor deposition, *Appl. Phys. Lett.* 79 (2001) 680-682.
- [76] B.O. Boskovic, V. Stolojan, R.U. Khan, S. Haq, S.R. Silva, Materials, Large-area synthesis of carbon nanofibres at room temperature, *Nature* 1 (2002) 165-168.
- [77] H. Dai, A.G. Rinzler, P. Nikolaev, A. Thess, D.T. Colbert, R.E. Smalley, Single-wall nanotubes produced by metal-catalyzed disproportionation of carbon monoxide, *J. Chem. Phys. Lett.* 260 (1996) 471-475.
- [78] W.K. Hsu, J.P. Hare, M. Terrones, H.W. Kroto, D.R.M. Walton, P.J.F. Harris, Condensed-phase nanotubes, *Nature* 377 (1995) 687-689.
- [79] W.K. Hsu, M. Terrones, J.P. Hare, H. Terrones, H.W. Kroto, D.R.M. Walton, Electrolytic formation of carbon nanostructures, *J. Chem. Phys. Lett.* 262 (1996) 161-166.
- [80] G.Z. Chen, D.J. Fray, Recent development in electrolytic formation of carbon nanotubes in molten salts, *J. Mini. Metal. B* 39(1-2) (2003) 309-342.
- [81] I.W. Chiang, B.E. Brinson, A.Y. Huang, P.A. Willis, M.J. Bronikowski, Purification and characterization of single-wall carbon nanotubes (SWNTs) obtained from the gas-phase decomposition of CO (HiPco process), *J. Chem. Phys. B* 105 (2001) 8297-8301.
- [82] I.W. Chiang, B.E. Brinson, R.E. Smalley, J.L. Margrave, R.H. Hauge, Purification and characterization of single-wall carbon nanotubes (SWNTs) obtained from the gas-phase decomposition of CO (HiPco process), *J. Chem. Phys. B* 105 (2001) 1157-1161.
- [83] A.R. Harutyunyan, B.K. Pradhan, J. Chang, G. Chen, Purification of single-wall carbon nanotubes by selective microwave heating of catalyst particles, *J. Chem. Phys. B* 106 (2002) 8671-8675.

- [84] C.J. Ko, C.Y. Lee, F.H. Ko, H.L. Chen, T.C. Chu, Highly efficient microwave-assisted purification of multi-walled carbon nanotubes, *J. Microelec. Eng.* 570 (2004) 73-74.
- [85] G. Hajime, F. Terumi, F. Yoshiya, O. Toshiyuki, Method of purifying single wall carbon nanotubes from metal catalyst impurities, Honda Giken Kogyo Kabushiki Kaisha, Japan, 2002.
- [86] E. Borowiak-Palen, T. Pichler, Reduced diameter distribution of single-wall carbon nanotubes by selective oxidation, *J. Chem. Phys. Lett.* 363 (2002) 567-572.
- [87] E. Farkas, M.E. Anderson, Z. H. Chen, A.G. Rinzler, Length sorting cut single wall carbon nanotubes by high performance liquid chromatography, *J. Chem. Phys. Lett.* 363 (2002) 111-116.
- [88] H. Kajiura, S. Tsutsui, H.J. Huang, Y. Murakami, High-quality single-walled carbon nanotubes from arc-produced soot, *J. Chem. Phys. Lett.* 364 (2002) 586-592.
- [89] B. McCarthy, J.N. Coleman, R. Czerw, A.B. Dalton, M. Panhuis, A. Maiti, et al, High-yield, nondestructive purification and quantification method for multiwalled carbon nanotubes, *J. Phys. Chem. B* 106 (2002) 3087-3091.
- [90] M. Cinke, J. Li, B. Chen, A. Cassell, L. Delzeit, J. Han, M. Meyyappan, Pore structure of raw and purified HiPco single-walled carbon nanotubes, *J. Chem. Phys. Lett.* 365(1-2) (2002) 69-74.
- [91] H.C. Shim, H.W. Lee, S. Yeom, Y.K. Kwak, S.S. Lee, S.H. Kim, Purification of carbon nanotubes through an electric field near the arranged microelectrodes, *J. Nanotechnol.* 18(11) (2007) 115602-115608.
- [92] W. Huang, Y. Wang, G. Luo, F. Wei, Purity multi-walled carbon nanotubes by vacuum high-temperature annealing, *Carbon* 41 (2003) 2585-2590.
- [93] M. Yudasaka, H. Kataura, T. Ichihashi, Diameter enlargement of HiPco single-wall carbon nanotubes by heat treatment, *Nano. Lett.* 1(9) (2001) 487-489.